

1 | 2 | 3 | 4 | 5 | 6 | 7 | 8

A

B

C

D

E

A

B

C

D

E

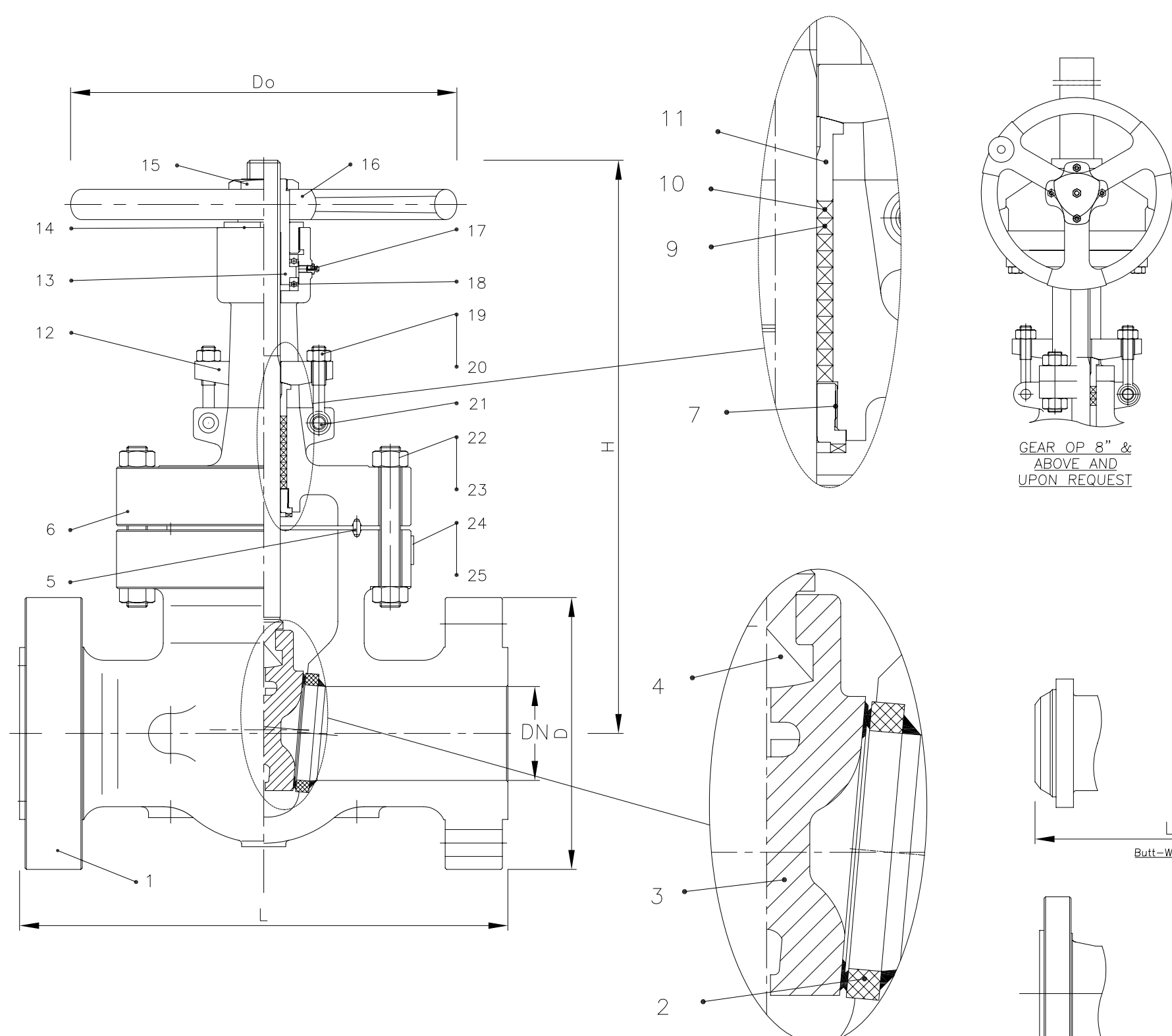

BILL OF MATERIALS				
NO.	DESIGNATION	QTY	MATERIAL	NOTES
1	Body	1	A216 WCB	
2	Seat Ring	2	A105+STL 6	
3	Wedge	1	A216 WCB+STL 6	
4	Stem	1	A182 F6a	
5	Gasket	1	A276 410	
6	Bonnet	1	A216 WCB	
7	Back Seat	1	A276 410	
8	*			
9	Packing	2	Braided Graphite	
10	Packing	4~5	Flexible Graphite	
11	Gland	1	A276 410	
12	Gland Flange	1	A216 WCB	
13	Stem Nut	1	A439 D-2	
14	Gland Nut	1	ANSI 1020	
15	Lock Nut	1	ANSI 1020	
16	Handwheel	1	A536 60-40-18	
17	Grease Nipple	1	Carbon Steel	
18	Bearing	2	UNS 52100	
19	Eye Bolt		A193 B7	
20	Eye Nut		A194 2H	
21	Pin	2	A108 1035	
22	Bolt		A193 B7	
23	Nut		A194 2H	
24	Rivet	2	304SS	
25	Name Plate	1	304SS	

GEAR OP 8" & ABOVE AND UPON REQUEST

Materials available on request: Stainless steel all grades; Duplex & Super Duplex; Chrome-moly; Inconel; Monel;

N.B	DN	L	L2	L3	D	Do	H(Open)	Wgt*
2"	43	368	368	371	216	300	539	74
3"	66	470	470	473	266	400	738	164
4"	92	546	546	549	311	500	783	234
6"	139	705	705	711	393	560	1196	555
8"	182	832	832	841	482	560	1546	1296
10"	230	991	991	1000	584	710	1688	1801
12"	273	1131	1131	1146	673	710	2090	3434
14"	300	1257	1257	1276	749	760	2163	3704
16"	344	1383	1383	1407	825	760	2486	6255

NOTE: BW Schedule to suit client order
* Wgt for RF valves only

DESIGN CODE	API 600/ANSI B16.34	TEST PRESSURES		
FACE TO FACE DIMENSIONS	ASME B16.10	BODY	153.15	Barg
ENDS FLANGES DIMENSIONS	ASME B16.5/B16.25	SEAT	112.31	Barg
TESTING CODE	API 598	BACKSEAT	112.31	Barg
		AIR - SEAT	6.0	Barg

REV	DATE	DESCRIPTION	BY	CHK	APP	SCALE:		
01	10/05/2010	Addition of RTJ flange dims				DRAWN	DM	DATE
						CHECKED	SMN	DATE
						APPROVED	AW	DATE

DRAWING TITLE:
API CAST CARBON STEEL CLASS 1500
BOLTED BONNET, RF/RTJ/BWE, GATE VALVES

CLIENT: .

VENDOR PO REF: .

EVC REF: .

CAD. No. DRAWING NUMBER: 120064-02 REV 00

AREA No. | FACILITY | TYPE | SEQ. No. | SHT. No.

MATERIALS TO NACE MR0175 LATEST EDITION (WETTED PARTS).

1 | 2 | 3 | 4 | 5 | 6 | 7 | 8